

Model: CAM5111

720P 1.0 Megapixels IR PTZ Speed Dome Network Camera

Features

1/4" 1.0 Megapixels Progressive Scan Sony CMOS

H.264 & MJPEG dual-stream encoding

Max 30fps@1.0Megapixels (1280x720)

WDR, Day/Night, AWB, AGC, BLC

Auto dimming technology by video analysis

With outer aluminum windshield wiper

Wall mounted bracket of waterproof power supply box integration

20X optical zoom

Micro SD Card Slot

Multiple network monitoring: Web viewer, CMS, Smart phone.

IP66 standard

Max IR distance 150M



Model: CAM5111

Specification

Model	CAM5111	
Dome Camera		
Image Sensor	1/4" 1.0 Megapixels Progressive Scan Sony Exmor CMOS	
Effective Pixels	1280x720	
Scanning System	Progressive	
Electronics Shutter Speed	Auto (1/25,1/30 ~ 1/10000s)	
Min. Illumination	0.25Lux/F1.35 (Color), 0.03Lux/F1.3(B/W); 0Lux IR ON	
S/N Ratio	>50dB	
Preset	256 Presets,	
Pan rotation range	360°	
Tilt range	180°	
Pan speed	0.01°-360°/S	
Vertical speed	0.01°-120°/S	
360° Scan	Auto Scanning	
Protocol (Available Camera)	Sony	
Baud rate (RS485)	1200 / 2400 / 4800 / 9600bps	
Camera Features		
Day/Night	Color / B/W	
Backlight Compensation	BLC / HLC / WDR (digital)	
White Balance	Auto	
Gain Control	Auto	
Noise Reduction	3D	
Privacy Masking	Up to 4 Areas	
Lens Zoom	20x Optical Zoom, 12x digital zoom	
Focal Length	F=3.5mm(W) ~70mm (T)	
Iris	F1.35~F3.4	
Focus Control	Manual	
Angle of View	55.9°(W)~2.1°(T)	
OSD	Supported	
WDR	Supported	
IR Infrared	8LEDs, IR Distance 150 Meters	
Video		
Compression	H.264 / MJPEG	
Resolution	1280x720 ; 640x320, 320x160, 160x112	
Frame Rate	Preferred Stream	1280x720 (1~25/30fps)
	Alternate Stream	640x320, 320x160, 160x112 (1~25/30fps)
Bit Rate	32KB ~16Mbps, support VBR, CBR	
Audio		
Compression	G.711a / G.711U, G.726	
Interface	1 Channel Input, 1 Channel Output	
Network		
Ethernet	RJ-45 (10/100Base-T)	
Protocol	IPv4/IPv6, HTTP, TCP/IP, UDP, RTP, RTCP, UPNP, RTSP, SMTP, NTP, DHCP, DNS, PPPOE, DDNS, FTP,	
ONVIF	ONVIF Ver. 2.0	

Model: CAM5111

Max. User Access	10 users
Smart Phone	iPhone, iPad, Android, Symbian
Auxiliary Interface	
Memory Slot	Micro SD, Max 32GB
Alarm	4-Alarm in and 2 Alarm output (AC120V, 1A ; DC 24C 1A)
PTZ control	RS485
General	
Power Supply	DC12V±10%
Power Consumption	≤50W
Working Environment	-30 °C ~ 60°C
Size	6 inch Alloy Case
Dimensions	Ø228x354x341mm
IP grade	IP66
Weight	6KG
Warranty	1 Year Advanced Replacement

Dimensions (mm)

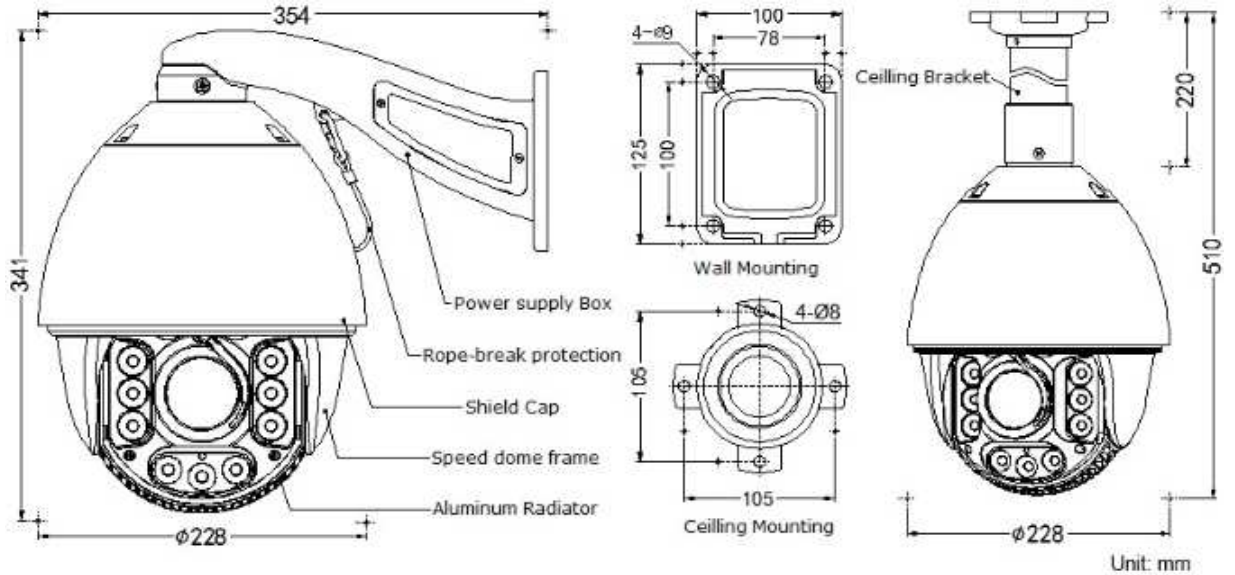

Bracket Optional:

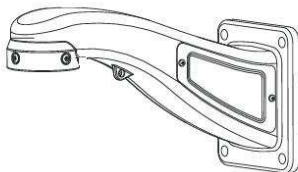

Wall-mounting



Ceiling -mounting