

## Model: CAM5211

1080P Full HD 2.1 Megapixel IR PTZ Speed Dome Network Camera

### Features

- 1/2.8" 2.1 Megapixel Progressive Scan Sony CMOS
- H.264 & MJPEG dual-stream encoding
- Max 25/30fps@ 2.1 Megapixel (1920x1080)
- WDR, Day/Night, AWB, AGC, BLC
- Auto dimming technology by video analysis
- With outer aluminum windshield wiper
- Wall mounted bracket of waterproof power supply box integration
- 20X optical zoom
- Micro SD Card Slot
- Multiple network monitoring: Web viewer, CMS, Smart phone
- IP66 standard
- Max IR distance 150M



# Model: CAM5211

## Specification

<b>Model</b>	<b>CAM5211</b>	
<b>Dome Camera</b>		
Image Sensor	1/2.8" 2.1 Megapixel Progressive Scan Sony CMOS	
Effective Pixels	1920x1080	
Scanning System	Progressive	
Electronics Shutter Speed	Auto (1/25,1/30 ~ 1/10000s)	
Min. Illumination	0.5Lux/F1.6 (Color), 0.05Lux/F1.6(B/W); 0Lux IR ON	
S/N Ratio	>50dB	
Preset	256 presets,	
Pan rotation range	360°	
Tilt range	180°	
Pan speed	0.01°-360°/S	
Vertical speed	0.01°-120°/S	
360° Scan	Auto scanning	
Protocol (Available camera)	Sony	
Baud rate (RS485)	1200 / 2400 / 4800 / 9600bps	
<b>Camera Features</b>		
Day/Night	Color / B/W	
Backlight Compensation	BLC / HLC / WDR (digital)	
White Balance	Auto	
Gain Control	Auto	
Noise Reduction	3D	
Privacy Masking	Up to 4 Areas	
Lens Zoom	20x optical zoom, 12x digital zoom	
Focal Length	F=4.7mm(W) ~94mm (T)	
Iris	F1.6~F3.5	
Focus Control	Manual	
Angle of View	55.4°(W)~2.9°(T)	
OSD	supported	
WDR	supported	
IR Infrared	8LEDs, IR distance 150 Meters	
<b>Video</b>		
Compression	H.264 / MJPEG	
Resolution	1920x1080, 1280x720 ; 640x320, 320x160, 160x112	
Frame Rate	Preferred Stream	1920x1080 (1~25/30fps), 1280x720 (1~25/30fps)
	Alternate Stream	640x320, 320x160, 160x112 (1~25/30fps)
Bit Rate	32KB ~16Mbps, support VBR, CBR	
<b>Audio</b>		
Compression	G.711a / G.711U, G.726	
Interface	1 channel Input, 1 channel Output	
<b>Network</b>		
Ethernet	RJ-45 (10/100Base-T)	
Protocol	IPv4/IPv6, HTTP, TCP/IP, UDP, RTP, RTCP, UPNP, RTSP, SMTP, NTP, DHCP, DNS, PPPOE, DDNS, FTP,	

**Model: CAM5211**

ONVIF	ONVIF Ver. 2.0
Max. User Access	10 users
Smart Phone	iPhone, iPad, Android, Symbian
<b>Auxiliary Interface</b>	
Memory Slot	Micro SD, Max 32GB
Alarm	4-Alarm in and 2 Alarm output (AC120V, 1A ; DC 24C 1A)
PTZ control	RS485
<b>General</b>	
Power Supply	DC12V±10%
Power Consumption	≤50W
Working Environment	-30 °C ~ 60°C
Size	6 inch Alloy Case
Dimensions	Ø228x354x341mm
IP grade	IP66 /secondary lightning protection, 3000KV Surge protection
Weight	6KG
Warranty	1 Year Advanced Replacement

**Dimensions (mm)**

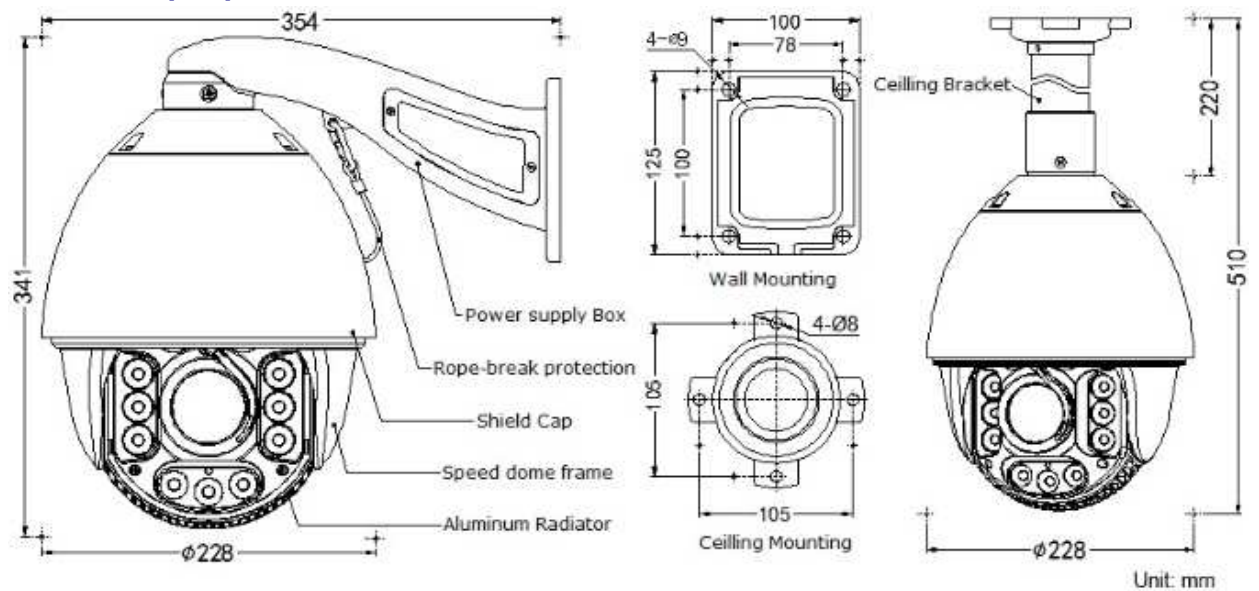

**Bracket Optional:**

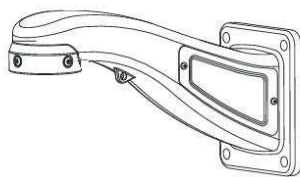

**Wall-mounting**

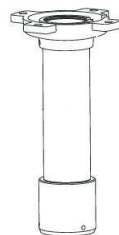

**Ceiling-mounting**